



Subject to modifications.

GEA TwinPANDA Lab Homogenizer 600

Technical data | Laboratory Homogenizer

This small table-top unit, designed for continuous operation at high pressure, is the perfect equipment for laboratory scale high pressure processing of dairy products, fruit juices, liquid food, food additives and ingredients.

Tests can be run even with small sample volumes, and the results can be scaled up on industrial homogenizers.

The machine is suitable for CIP and SIP.

Main options

- Variable capacity (50% - 100%) with frequency converter
- Aseptic execution
- 3-A execution
- FDA approved gaskets and cGMP documentation

Technical data

Number of plungers	2
Net weight	150 kg
Gross weight	180 kg
Dimensions (mm)	W 523 x H505 x L 839
Minimum sample volume	approx. 500 ml
Noise level	≤70 dB(A) ± 2
Feeding hopper volume	2,5 l

Technical data | Laboratory Homogenizer

Liquid end

- High grade and high performance Super Duplex stainless steel and special high wear resistant material
- Solid ceramic pumping plungers
- Suction and delivery ball valves (PVB) in tungsten carbide, with replaceable suction valve seat in tungsten carbide
- Pressure transmitter with 4-20 mA remote pressure signal

Homogenizing valve

- Manual pressure adjustment by means of a hand-wheel
- Reversible wear parts in tungsten carbide
- Second stage as standard

Power end

- AC motor drive, suitable for variable speed drive
- Camshaft drive system and maintenance-free grease lubrication
- Maintenance-free timing belt drive

Casing

- Panels made in polished stainless steel, completely removable for maintenance and cleaning
- High quality shot peening stainless steel base frame
- Adjustable anti-vibration rubber feet

Safety kit

- Plastic control board fixed inside the machine
- Emergency pushbutton
- Start/stop pushbutton
- Built-in safety protection against overpressure

Product inlet/outlet

- 1/2" Tri-Clamp™
- Tri-Clamp™ connections for inline installation
- No feeding pump is needed (for product viscosity up to 1.000 cP)
- SS feeding hopper (2,5 l) supplied as standard

Dimensional drawing

Overall dimensions (mm)

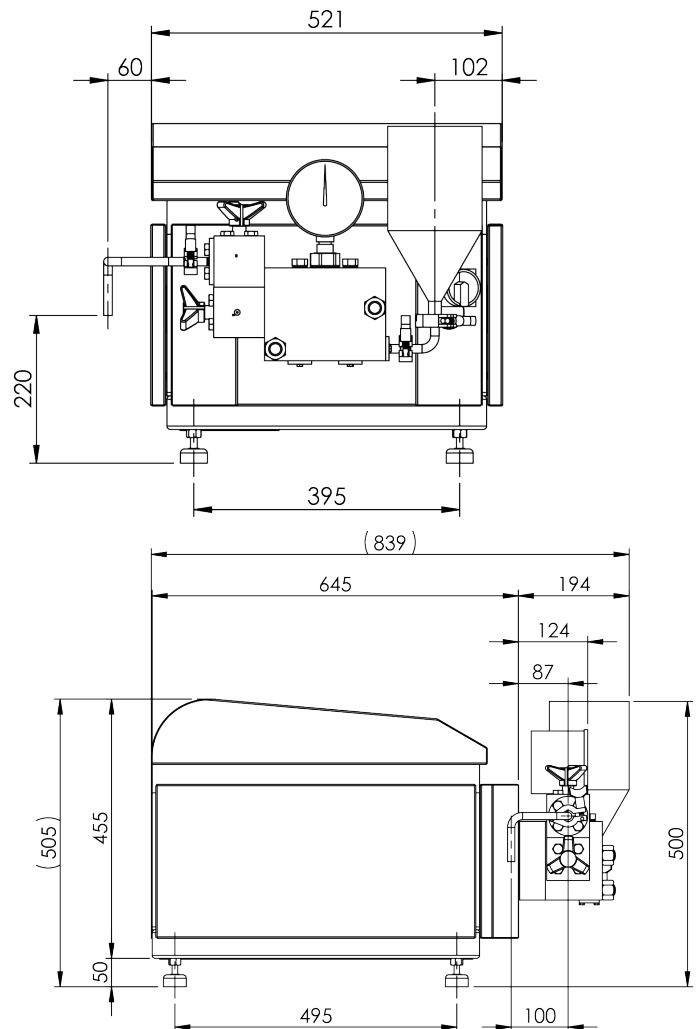

Flow Rate (l/h)	Pressure (bar)	Electrical Supply (Hz)
30	600	50/60

GEA Mechanical Equipment Italia S.p.A.

Via A.M. Da Erba Edoari, 29
43123 Parma, Italy

Tel +39 0521 965411
gea.com/contact