



Subject to modifications.

GEA Panther Lab Homogenizer 3006

Technical data | Pilot Unit & Laboratory Homogenizer

GEA Panther Lab Homogenizer 3006 is a standalone fully equipped laboratory unit for small productions or tests, featuring the performances of the industrial scale homogenizers.

The unit is designed for continuous operation up to 1500 bar and its compact design allows at the same time easy installation, simple operation and quick maintenance.

Suitable also for viscous products, it can be used in many different industries such as food, dairy, beverage, chemical, pharmaceutical, cosmetics and biotech. The machine is suitable for CIP and SIP.

Main options

- Electropolished version (Ra 0.5 μm)
- Aseptic execution
- 3-A execution
- FDA approved gaskets and cGMP documentation
- Pharma validation protocols
- Spare part package

Technical data

Number of plungers	3
Absorbed motor power up to	5,5 kW
Net weight	560 kg
Gross weight	730 kg
Noise level	$\leq 72 \text{ dB(A)} \pm 2$
Feeding hopper volume	4,5 l

Technical data | Pilot Unit & Laboratory Homogenizer

Liquid end

- High grade and high performance Super Duplex stainless steel and special high wear resistant material
- Solid ceramic pumping plungers equipped with specially designed packing for very high pressure applications including flow switch for lubricating water
- Suction and delivery ball valves (PVB) in special alloy, highly resistant to abrasion, with replaceable valve seats in Stellite™
- Sanitary design analog pressure gauge
- Multiblock design

Homogenizing valve

- Rupture type Re+ homogenizing valve
- Manual pressure adjustment by means of a hand-wheel
- Second stage supplied as standard
- Wear parts made of tungsten carbide or ceramics as option

Power end

- Cast iron power frame
- "V" belts drive and gearbox speed reduction unit
- AC motor drive
- Splash type lubrication system, forced as option

Casing

- Polished stainless steel with removable panels for east access and maintenance
- Stainless steel AISI 304 base frame
- Polished SS machine casing on galvanized steel frame
- The machine is mounted on castors for easy handling

Control panel

- Electric Power Board (IP55 protection) located inside the machine casing. Assembled according to CE standards
- Homogenizer and feed pump start/stop push buttons
- Pump speed adjustment

Product inlet/outlet

- Stainless steel feeding funnel (5 l capacity) with connecting pipework to the feeding pump (inclusive of 10 Mesh filter and Tri-clamp fittings)
- Lobe type pump driven by a separate electric motor with built in variable speed drive unit to adjust the feed pressure according to the product viscosity. All product contact parts are in AISI 316
- By-pass valve for recirculating the product into the funnel and pressure gauge to read the inlet pressure
- Product heat exchanger as option

Safety devices

- Spring loaded overpressure relief valve
- Emergency push button

Product line connections

- Tri-Clamp™

Dimensional drawing

Overall dimensions (mm)

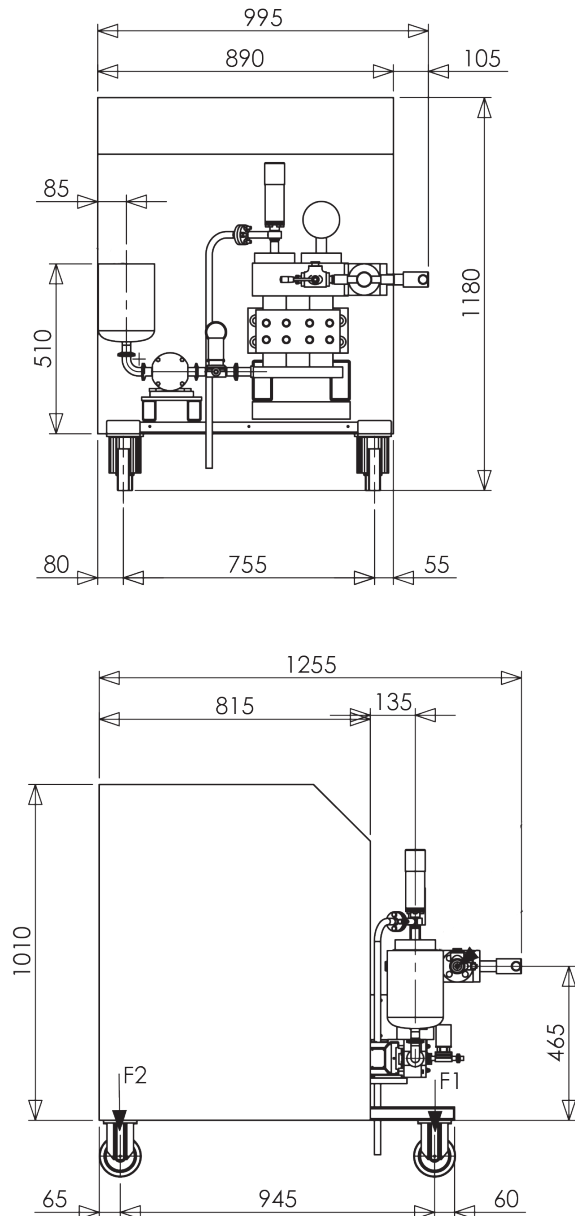

Performance

Pressure (bar)	Max Flow Rate (l/h)
1.000	120
1.200	120
1.500	50

Each line refers to a different machine, which is designed for the specified maximum pressure and maximum capacity in the above table.

GEA Mechanical Equipment Italia S.p.A.

Via A.M. Da Erba Edoari, 29
43123 Parma, Italy

Tel +39 0521 965411
gea.com/contact