



GEA One Homogenizer 11TS

Technical data | High Pressure Homogenizer

The One series homogenizers, compliant to EU safety rules (CE standards) and built according to EN ISO 9001:2008 Quality System, are the best fit for dairy, food & beverage applications.

Available up to 250 bar, suitable for CIP and SIP, the One machines are the fit for purpose solution for small and medium size process line. The energy efficient solution of One range allows to reduce consumptions and optimize the running costs.

Main options

- 2nd stage homogenizing valve
- Electric power board inside the machine casing (access from the back)
- Inlet/outlet pulsation dampners
- Inlet pressure transducer with display and low pressure alarm
- Solenoid valves for water and air
- Built in electrical powerboard

Sustainability values

Energy consumption/1000 l product (kWh)	5
Water consumption/1000 l product (l)	40,9
Lubricating and cooling water	90 l/h
Oil consumption ISO VG 150	9 l/2.000 h
Noise level	≤78 dB(A) ± 2
Carbon footprint/1000 l product (kg CO ₂)	2,5

Technical data

Number of plungers	3
Absorbed motor power up to	11 kW
Net weight	850 kg
Gross weight	1.000 kg

Process data

Sanitary execution: max. capacity at 150 bar; water max. hardness <15°fH, max. particle size 60 microns, filtered water; noise level at max. capacity and max. pressure at 1 meter distance; CO₂ emissions based on electricity production generating 0,5 kg CO₂/kWh.

Technical data | High Pressure Homogenizer

Liquid end

- Engineered with a reduced number of parts for simplified use and maintenance
- High quality forged stainless steel and special high wear resistant materials for best mechanical and corrosion resistance performance
- Monoblock construction compression head

Homogenizing valve

- Wear parts in solid tungsten carbide for extended operation
- One stage with pneumatic adjustment from the machine's control panel
- Second stage as option

Power end

- Cast iron power frame
- Heavy duty and reliable power frame housing the transmission elements
- AC motor drive
- Splash lubrication
- "V" belts drive/Direct belt drive
- Forged special alloy steel crankshaft on roller bearings

Casing

- Polished stainless steel machine casing on galvanized steel frame
- Easy access and maintenance with removable panels
- Stainless steel terminal box

Plungers

- Chrome coated stainless steel
- Self centering clamped connection

Pump valves

- SS alloy removable and reversible valve seats
- Ball type (PVB) pumping valves in SS alloy

Pressure measurement & control

- Sanitary design analog high pressure gauge

Safety devices

- Overpressure relief valve installed on the compression block
- Version with handle as option
- Emergency push button with reset

Product line connections

- DIN 11851 fittings
- Tri-Clamp™ fittings

Tools and spare parts

- Ordinary maintenance tools and one set of emergency spare parts supplied with the machine
- O&M manual and spare part list on USB stick

Dimensional drawing

Overall dimensions (mm)

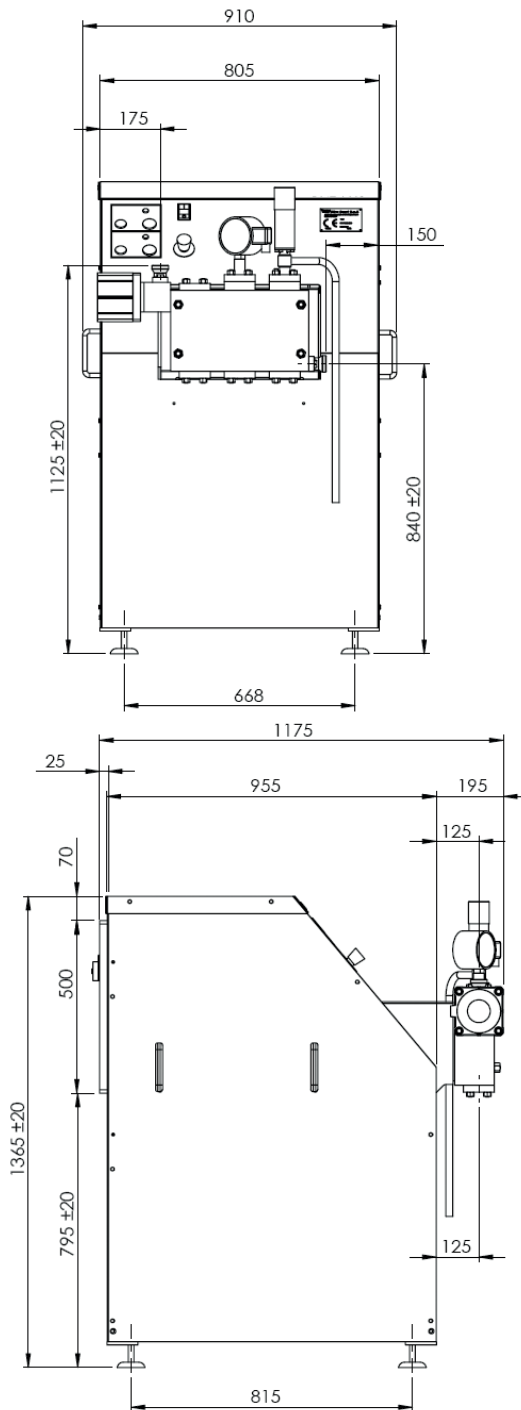

Performance	
Pressure (bar)	Max Flow Rate (l/h)
100	3.300
130	2.500
150	2.200
180	1.800

Performance	
Pressure (bar)	Max Flow Rate (l/h)
200	1.650
210	1.550
250	1.300

Each line refers to a different machine, which is designed for the specified maximum pressure and maximum capacity in the above table.

GEA Mechanical Equipment Italia S.p.A.

Via A.M. Da Erba Edoari, 29
43123 Parma, Italy

Tel +39 0521 965411
gea.com/contact