



Subject to modifications.

# GEA Ariete Homogenizer 3055

## Technical data | Homogenizer & High Pressure Pump

The Ariete Series is the state-of-the-art for powerful reliable high pressure machines and customized solutions. The Ariete machines, compliant to EU safety rules (CE standards) and built according to EN ISO 9001:2008 Quality System, are the best fit for pharmaceutical, dairy, food & beverage, biotech, chemical and cosmetics industries.

Suitable for CIP and SIP, the Ariete Series can be supplied with all necessary customizations for easy integration in any process line. The wide range of available materials, the low running speed (max. 185 rpm) and linear plunger velocity allow Ariete machines to perform at their best also on abrasive and viscous product.

### Main options

- 2<sup>nd</sup> stage homogenizing valve
- Electric power board for fixed or variable capacity
- Machine automation and remote controls
- Aseptic execution
- 3-A execution
- FDA approved gaskets and cGMP documentation

### Sustainability options

- NanoVALVE™
- Oil Purification System
- NiSoPURE

### Sustainability values

Energy consumption/1000 l product (kWh)	4,5
Water consumption/1000 l product (l)	7,5
Lubricating and cooling water	90 l/h
Oil consumption ISO VG 150	30 l/2.000 h
Oil consumption EP 220	17 l/20.000 h
Noise level	≤78 dB(A) ± 2
Carbon footprint/1000 l product (kg CO <sub>2</sub> )	2,29

### Technical data

Number of plungers	3
Absorbed motor power up to	55 kW
Net weight	2.300 kg
Gross weight	2.685 kg

### Process data

Sanitary execution: max. capacity at 150 bar; water max. hardness <15°fH, max. particle size 60 microns, filtered water; noise level at max. capacity and max. pressure at 1 meter distance; CO<sub>2</sub> emissions based on electricity production generating 0,5 kg CO<sub>2</sub>/kWh.

# Technical data | Homogenizer & High Pressure Pump

## Liquid end

- High quality stainless steel and special high wear resistant materials for best mechanical and corrosion resistance performance
- 3-A and electropolished versions available
- Ball (PVB) and poppet valves (PVP) interchangeable into the same block design for maximum product handling flexibility
- Aseptic version compression block available as option, with sterile condensate packing flushing
- Various materials for pumping plungers
- Monoblock construction up to 600 bar, forged high grade Duplex or Super Duplex SS alloy

## Homogenizing valve

- One stage (standard on homogenizers) with pneumatic adjustment from the machine's control panel
- NanoVALVE™, high efficiency homogenizing valve, available as option
- Engineered for easy maintenance and cleaning
- Second stage as option
- Wear parts made of tungsten carbide, ceramics as option

## Power end

- Cast iron power frame
- Heavy duty and reliable power frame housing the transmission elements
- G-FX drive System for gearbox
- "V" belts drive and gearbox speed reduction unit
- AC motor drive
- Forced lubrication with gear pump, low oil pressure switch and oil cooling

## Casing

- Made of polished stainless steel with sound proof lining
- Easy access and maintenance with removable panels
- Noise reduction execution ( $\leq 75\text{dB(A)} \pm 2$ ) available as options

## Plungers

- Chrome coated stainless steel
- Tungsten carbide coated stainless steel
- Solid ceramic
- HCR Chromium Carbide coated stainless steel

## Pump valves

- High wear resistant Stellite™ alloy removable seats
- Ball type (PVB) or poppet type (PVP) in solid Stellite™
- Tungsten carbide materials available as option

## Pressure measurement & control

- Sanitary design analog high pressure gauge
- Pressure transmitters and transducers available as option

## Safety devices

- Overpressure relief valve installed on the compression block available as option in different versions according to customer applications
- Emergency push button with reset
- Stainless steel compression head cover

## Product line connections

- DIN 11851, Tri-Clamp™, GEA Tuchenhagen Varivent™
- Others as option upon request

## Tools and spare parts

- Ordinary maintenance tools and one set of emergency spare parts supplied with the machine
- O&M manual and spare part list on USB stick

## Dimensional drawing

Overall dimensions (mm)

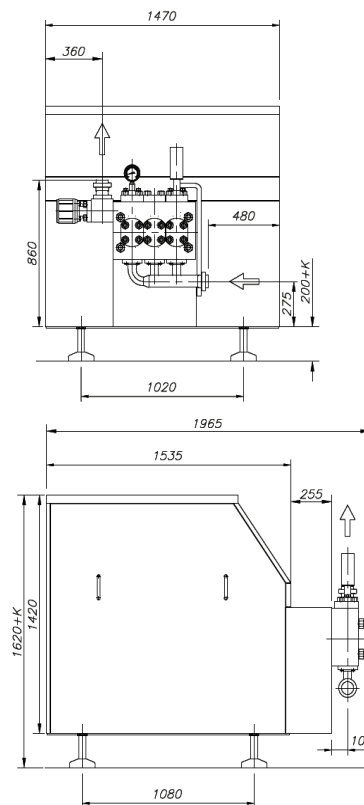

Performance	
Pressure (bar)	Max Flow Rate (l/h)
100	14.000
150	12.000
200	9.000
250	7.200
300	6.000

Performance	
Pressure (bar)	Max Flow Rate (l/h)
350	5.100
400	4.500
500	3.500
600	2.800

Each line refers to a different machine, which is designed for the specified maximum pressure and maximum capacity in the above table.

GEA Mechanical Equipment Italia S.p.A.

Via A.M. Da Erba Edoari, 29  
43123 Parma, Italy

Tel +39 0521 965411  
gea.com/contact